



# How to Install Calvert Racing CalTracs Traction Bars

417-683-6535 or info@willoughbyhotrods.com

Each of the two assemblies needed is comprised of three basic components shown in the illustration below:

The combination of these components changes the pushing point on the car by redirecting the turning action (spring wrap-up) of the rear axle through the Force Transfer Link into the Front Pivot. The Front Pivot Spring Stop resists this turning motion and also controls the bending of the leaf spring at its thinnest section. The push into the Front Pivot helps the cars weight shift towards the rear of the car because of the new directed angle of force toward the front of the vehicle. (The "Instant Center" moves farther forward). This is where the system emulates a Four Link System. The pinion angle is also maintained.

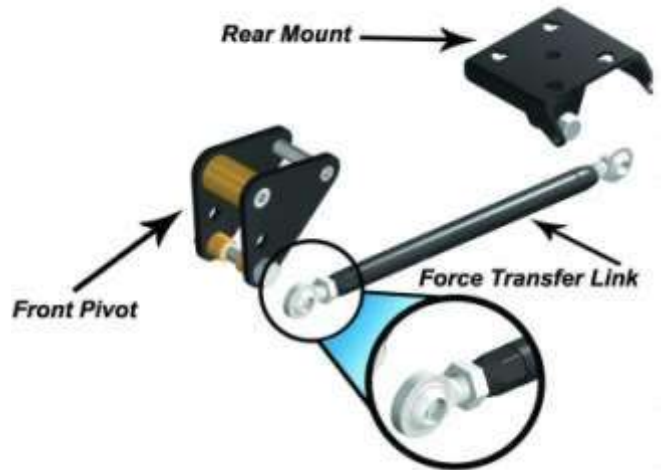

## INSTALLATION GUIDE

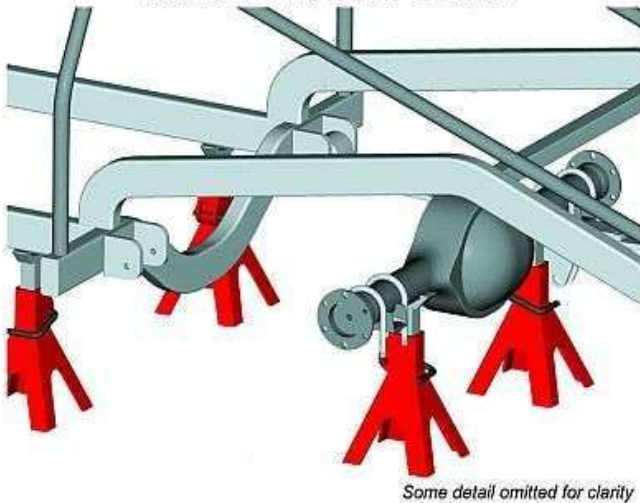

Some detail omitted for clarity

Raise and safely support the car high enough to remove the rear tires. Allow adequate working space. Next, the rear spring assemblies should be removed. This will facilitate replacement of the front eye bushings. To do this, support the rear end housing in place using a pair of jack stands on the axle and add another jack stand on the pinion yoke (to prevent the rear-end from turning nose down). This will eliminate the need to disconnect the drive shaft, brake lines, etc. Following that

would be to simply remove the springs.

Press or have pressed, the original **front** spring eye bushing out of each spring assembly. Replace these with the machined aluminum CalTracs bushings supplied in the kit.

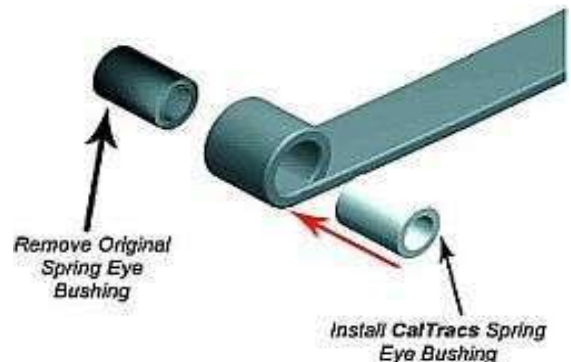

Now you are ready to install the CalTracs and reinstall the rear springs into the car.

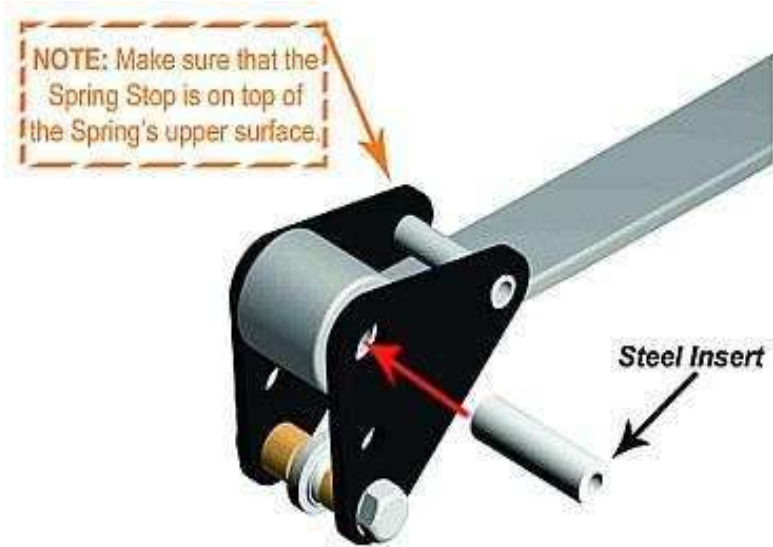

With each spring assembly ready to go in, position the Front Pivot assembly to the front spring eye. (Assure that the Spring Stop is located on the upper surface of the spring). Install the Steel Insert through the pivot and front spring eye bushing. Now, reinstall the spring using the original hardware. Repeat the process for the other side.

Lower the rear axle assembly on to the springs. Install the supplied Rear Mounts as you would the stock items being replaced. Attach the shocks.

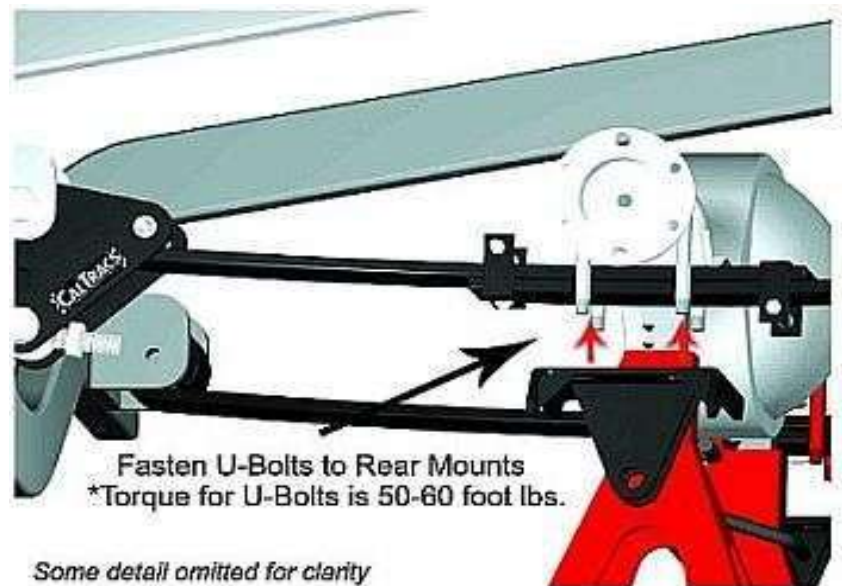

Now, the Force Transfer Link can be installed.

First, remove the Rear Mount rod end from the Mount assembly.

Second, jack the rear end up until the vehicles weight is fully supported by the suspension but leave the jack stands under the car. Next, install the Force Transfer Link by starting the **Hex** (wrenching) end on to the **Forward Rod End** and start the rear rod end (from the spring perch) into its threads at the rear Force Transfer Link. Adjust the assembly to proper length by holding the rear rod end then rotating the Force Transfer Link until the rear rod end will line up with the mounting hole in the rear spring perch. Install the rear rod end fastener and secure.

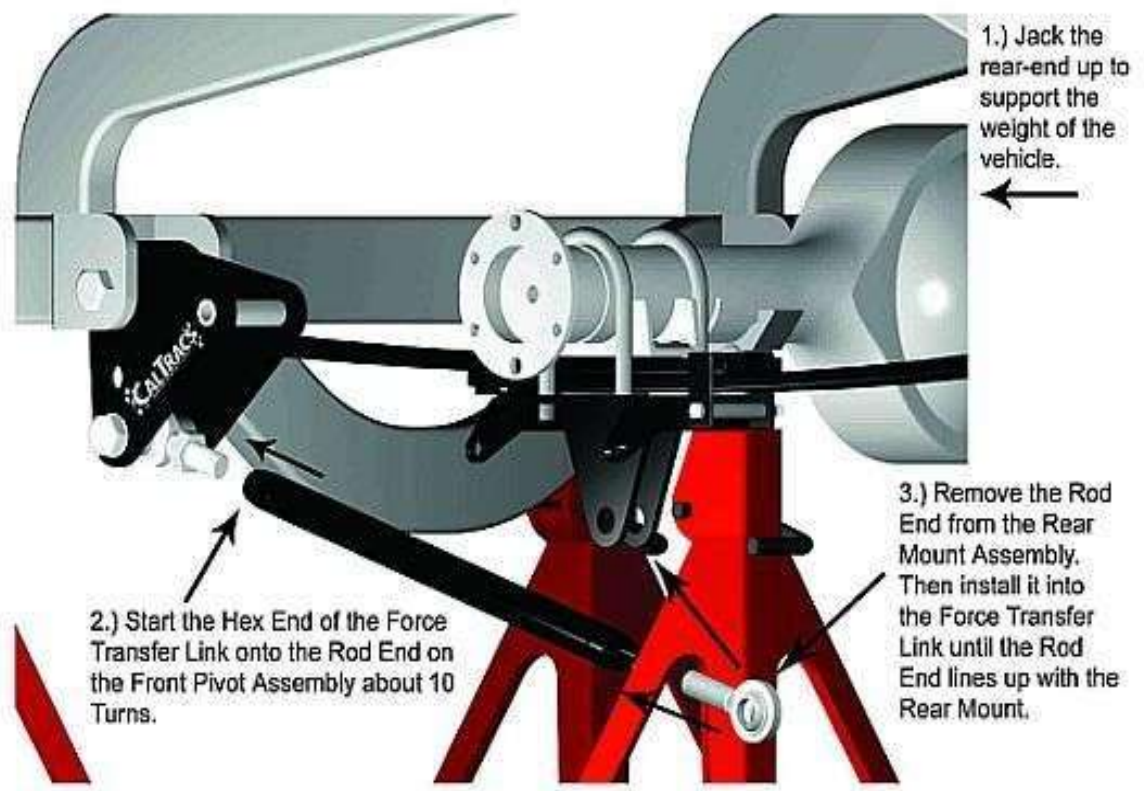

With CalTracs installed, reinstall the rear tires and lower the car to the ground. For an initial setting, have the driver in the car, (or a similar amount of weight). Turn the Force Transfer Link until the Spring Stop Bolt just contacts the upper surface of the spring, then turn the Force Transfer Link 1/2 Turn evenly side to side to establish pre-load. Tighten the Force Transfer Link lock nut. **All done!**

If you need further instruction or have any questions, please contact us at **417-683-6535** or **info@willoughbyhotrods.com**.

CalTracs is a product of Calvert Racing and holds a U.S. Patent

Instructions Courtesy of Calvert Racing Suspensions